

Manual

Software L-LAS-TB-Scope V3.01

(PC software for Microsoft® Windows® Vista, XP, 2000, NT® 4.0, Me, 98)

for laser line sensors of the L-LAS-TB series

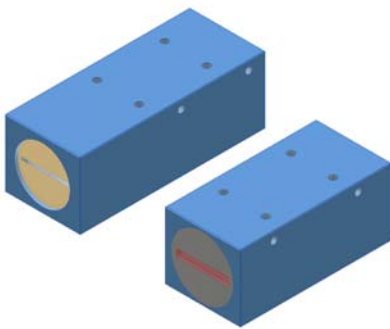

Split version, e.g.

L-LAS-TB-12
L-LAS-TB-25
L-LAS-TB-35
L-LAS-TB-55
L-LAS-TB-75
L-LAS-TB-100

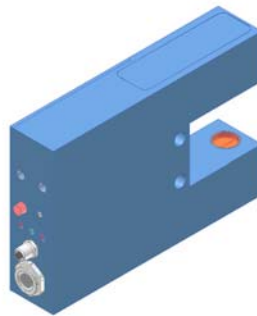

Fork-type version, e.g.

L-LAS-TB-F-(8)-30/40
L-LAS-TB-F-(16)-30/40

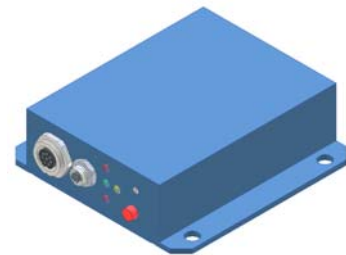

Split version with separate electronic control unit, e.g.

L-LAS-TB-8-CON1
L-LAS-TB-8-CON2
L-LAS-TB-12-CON1

0 Contents

Chapter	Page
1. Functional principle: L-LAS-TB control unit	3
1.1 Technical description.....	3
2. Installation of the L-LAS-TB-Scope software	4
3. Operation of the L-LAS-TB-Scope software	6
3.1 Control elements of the L-LAS-TB-Scope software	7
3.2 Numeric and graphic display elements	14
3.3 Serial RS232 data transfer	16
3.4 L-LAS-TB-Scope as an aid for sensor adjustment.....	17
3.5 L-LAS-TB-Scope as an aid for transmitter power adjustment.....	18
4. Evaluation modes.....	19
4.1 LEFT-EDGE	19
4.2 RIGHT-EDGE	19
4.3 WIDTH.....	20
4.4 CENTER.....	20
5. Two-point calibration	21
6. Annex.....	24
6.1 Laser warning	24
6.2 Function of the TEACH/RESET button	24
6.3 Function of the tolerance potentiometer.....	24
6.4 Function of digital inputs IN0 and IN1	25
6.5 Connector assignment	26
6.6 RS232 interface protocol.....	27

1 Functional principle: *L-LAS-TB* control unit

1.1 Technical description

In the laser line sensors of the *L-LAS series* the laser beam of a laser diode ($\lambda=670\text{nm}$, 1mW power, laser class 2) through suitable collimators and apertures is emitted from the optical transmitter unit as a laser line, i.e. as parallel laser light with homogeneous light distribution. In the optical receiver unit the laser line impinges on a CCD line receiver. This CCD line comprises many closely adjacent individual receiver elements (pixels) that are arranged in a line. The light quantity of each of these receiver elements that is collected during the integration time can be separately read out as an analog voltage and, after performing analog-digital conversion, can be stored in a data field as a digital value.

When there is a non-transparent measuring object in the laser line, the parallel laser light only illuminates those receiver elements (pixels) of the line that lie outside the shadow zone of the measuring object. As a result the pixels within the shadow zone give off a considerably lower analog voltage compared to the illuminated pixels. By way of suitable software algorithms the areas of the shadow zones can be determined from the previously stored data field. Since the distance of the pixels on the CCD line is known, the size and position of the measuring object can therefore be determined. The micro-controller of the *L-LAS-TB* sensor can be parameterized through the serial RS232 interface by means of a Windows PC software. The sensor can be set to operate with different evaluation modes. The housing of the control unit features a TEACH/RESET button and a potentiometer for tolerance setting. Switching states are visualized by means of 4 LEDs (1x green, 1x yellow, and 2x red) that are integrated in the housing of the *L-LAS*-sensor. The *L-LAS-TB* control unit has three digital outputs (OUT0, OUT1, OUT2), the output polarity of which can be set with the software. Two digital inputs (IN0, IN1) make it possible to realize an external TEACH/RESET functionality and an external TRIGGER functionality through a PLC. In addition the control unit features a high-speed analog output (0 ... 10V) with 12-bit digital/analog resolution.

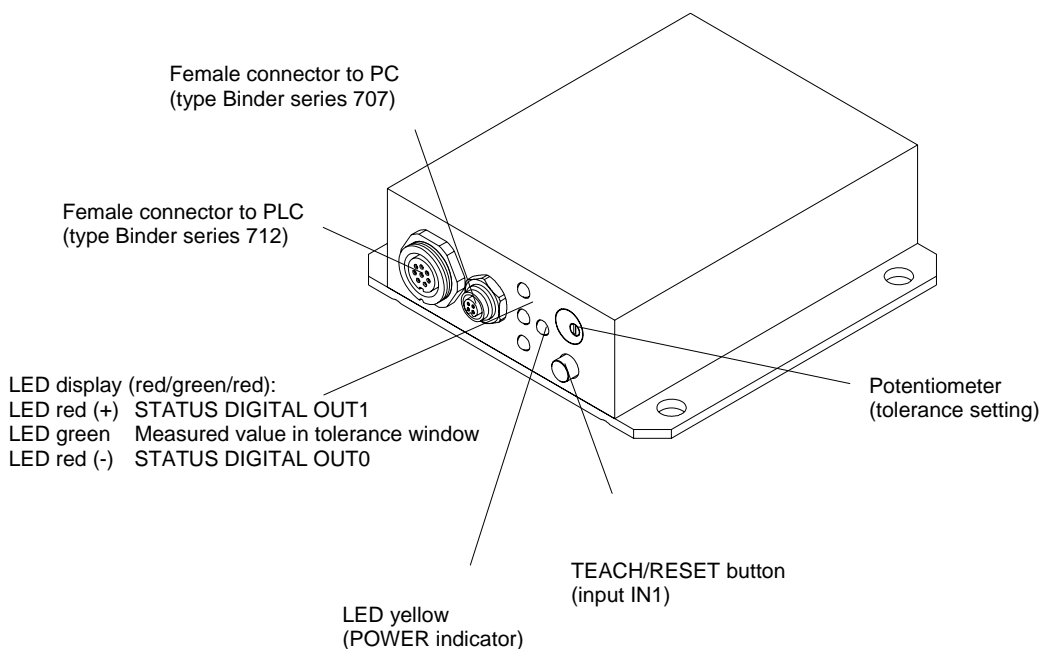



2 Installation of the *L-LAS-TB-Scope* software

Hardware requirements for successful installation of the *L-LAS-TB-Scope* software:

- 100 MHz Pentium-compatible processor or better.
- CD-ROM or DVD-ROM drive
- Approx. 8 MByte of free hard disk space
- SVGA graphics card with at least 800x600 pixel resolution and 256 colors or better.
- Windows 98, Windows NT4.0, Windows 2000, or Windows XP operating system
- Free serial RS232 interface or USB port with USB-RS/232 adaptor at the PC

Please install the *L-LAS-TB-Scope* software as described below:

1.  **CD-Laufwerk (D:)** Insert the installation CD-ROM in your CD-ROM drive. In our example we suppose that this is drive "D".

2.  **setup.exe** Start the Windows Explorer and in the folder tree of your CD-ROM drive go to the installation folder D:\Install\ . Then start the installation program by double-clicking on the SETUP.EXE symbol.

As an alternative, software installation can also be started by clicking on **START-Run...** and then entering "D:\Install\setup.exe", which must be confirmed by pressing the **OK** button.

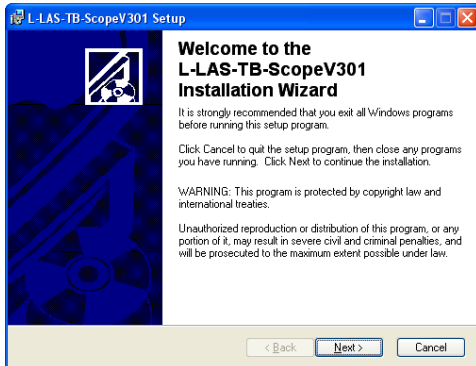

The installation program then displays a dialog box for *L-LAS-TB-Scope* installation.

This dialog box shows some general information about installation.

Click on **Next>** to start the installation

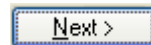

or on **Cancel** to quit the installation of the *L-LAS-TB-Scope* software

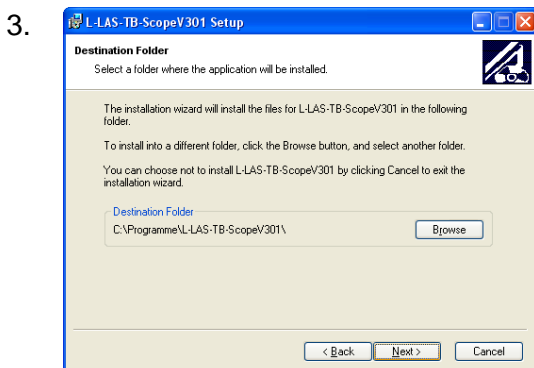
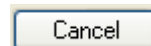

When you click on the **Next>** button, a new dialog appears for selecting the folder where the application will be installed (destination folder).

You may accept the suggested folder with **Next>**, or you may change the installation folder as desired by clicking on the **Browse** button.

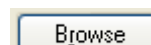

4.

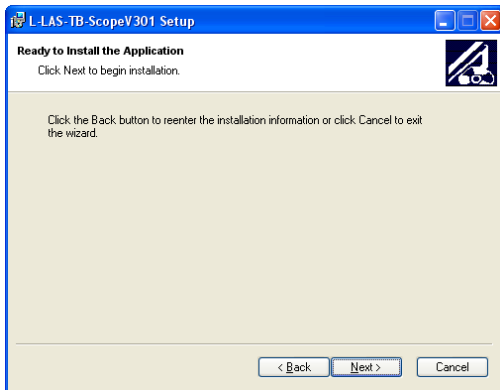

Another *L-LAS-TB-Scope* Setup dialog will be displayed.

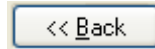

Click on the **Back** button if you want to change the installation folder again.

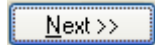

Click on **Next>>** to start the installation, or



click on **Cancel** to quit the installation process.

5.

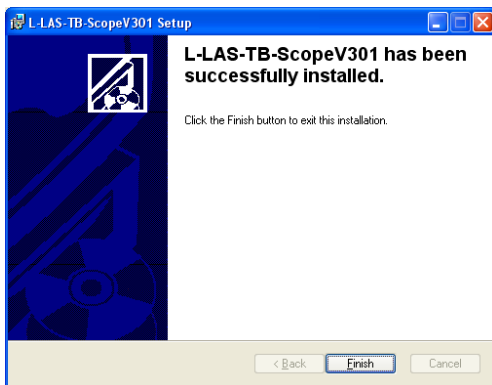

When installation is completed, a dialog box informs you about successful installation.

A new *L-LAS-TB-Scope* program group has been created under Start-All-Programs.



Click on the **Finish** button to finish the installation.



The *L-LAS-TB-Scope* software can now be started by clicking on the respective icon in the newly created program group under:

Start >All Programs > L-LAS-TB -ScopeV3.01

Deinstallation of the L-LAS-TB-Scope software:



Software

Please use the Windows deinstallation tool to remove the software.

The Windows deinstallation tool can be found under Start / Settings / Control Panel.

3 Operation of the *L-LAS-TB-Scope* software

The *L-LAS-TB-Scope* software is used for parameterizing the electronic control unit used for controlling the *L-LAS* line sensors. The measured values provided by the sensor can be visualized with the PC software, which means that the software among others can be used for adjustment purposes and for setting suitable tolerance limits for the inspection of the measuring object.

Data exchange between the PC user interface and the sensor system is effected through a standard RS232 interface. For this purpose the sensor is connected to the PC with the serial interface cable *cab-las-4/PC*. When parameterization is finished, the setting values can be permanently saved in an EEPROM memory of the *L-LAS-TB* control unit. The sensor system then continues to operate in "STAND-ALONE" mode without the PC.

When the *L-LAS-TB-Scope* software is started, the following Windows® user interface will be displayed:

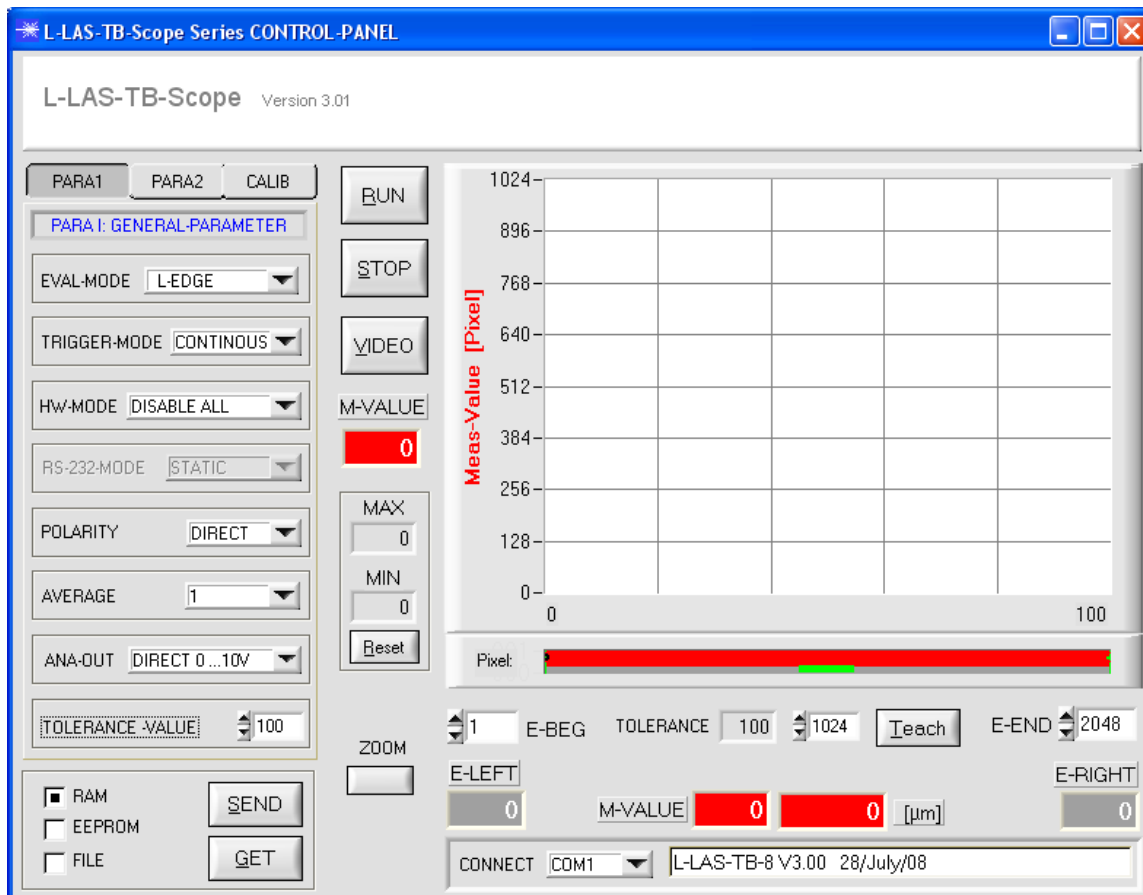

The *L-LAS-TB-Scope* CONTROL PANEL provides a great variety of functions:

- Visualization of measurement data in numeric and graphic output fields.
- Setting of the laser power for the laser transmitter.
- Setting of the polarity of the digital switching outputs OUT0, OUT1, and OUT2.
- Selection of a suitable evaluation mode.
- Presetting of setpoint value and tolerance band.
- Saving of parameters to the RAM, EEPROM memory of the control unit, or to a configuration file on the hard disk of the PC.

The following chapters provide explanations of the individual control elements of the *L-LAS-TB-Scope* software.

3.1 Control elements of the L-LAS-TB-Scope software:

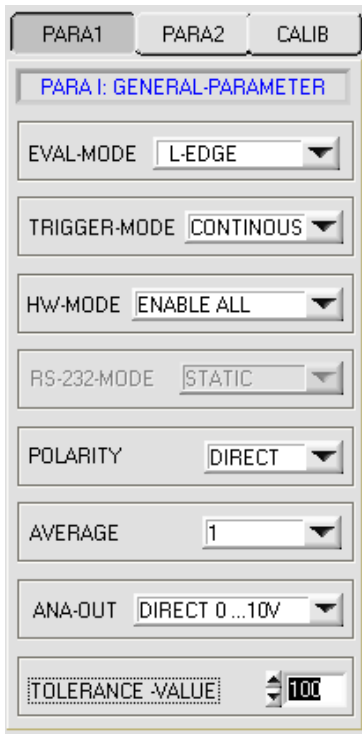

A click on the PARA 1 button opens the PARAMETER I window, where various parameters at the control unit can be set.



Attention !



Changes that are made in the function fields described below only become active at the control unit of the L-LAS-TB sensor after a click on the SEND button!

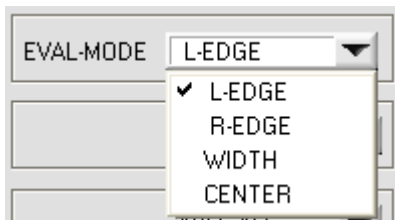

EVAL-MODE:

This list selection field serves for setting the evaluation mode at the L-LAS-TB sensor. Depending on the evaluation mode that is currently set, the edges created from the video signal (intensity profile) of the CCD line will be assessed differently.

L-EDGE:

The 1st edge (left edge) of the CCD line's intensity profile is used as measurement value.

R-EDGE:

The 2nd edge (right edge) of the CCD line's intensity profile is used as measurement value.

WIDTH:

The difference between the second and the first edge is used as measurement value: $WIDTH = R-EDGE - L-EDGE$

CENTER:

The mean value of the first edge and the second edge is used as measurement value: $CENTER = (L-EDGE + R-EDGE) / 2$

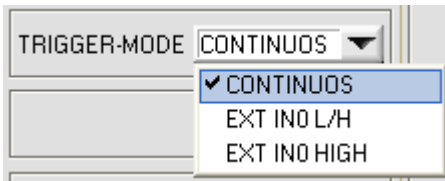

TRIGGER-MODE:

CONTINUOUS:

Continuous evaluation of the current measurement values.

EXT. IN0 L/H:

External edge-controlled (LOW/HIGH) triggering of measurement value evaluation through digital input IN0/pin3/green at the 8-pol. PLC female connector.

EXT. IN0 HIGH:

External triggering of measurement value evaluation by a high-level (+Ub) at digital input IN0/pin3/green.

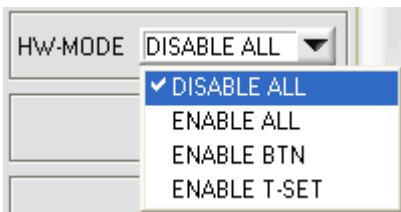

HARDWARE (Hardware-Mode):

The TOLERANCE potentiometer and the TEACH/RESET button at the housing of the *L-LAS-TB* sensor can be activated (ENABLE) or deactivated (DISABLE) by clicking on the respective item in the list selection field.

The TOLERANCE potentiometer allows the presetting of a tolerance window around the setpoint value. If the function field is set to ENABLE ALL or ENABLE T-SET, it is not possible to enter numerical values in the TOLERANCE-VALUE input field of the PC software. The respective function field will be grayed.

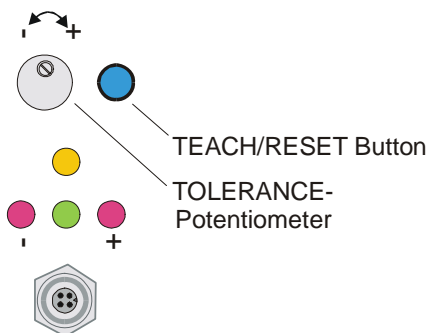

DISABLE ALL

Both the TEACH/RESET button and the TOLERANCE potentiometer at the housing are deactivated.

ENABLE ALL:

The TOLERANCE potentiometer at the housing is activated. (clockwise turning increases the tolerance bandwidth)
The TEACH/RESET button at the housing is activated.
Button pressed for a short time ($t < 0.7s$) : RESET function.
Button pressed for a long time ($t > 1.5s$) : TEACH function.

ENABLE BTN:

Only the TEACH/RESET button at the housing is activated.

ENABLE T-SET:

Only the TOLERANCE potentiometer at the housing is activated.

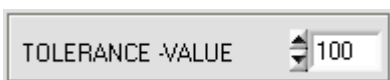

TOLERANCE-VALUE:

In this input field a tolerance value for the tolerance window can be set by entering a numerical value or by clicking on the arrows. The tolerance window is applied symmetrically around the setpoint value (TEACH-VALUE).

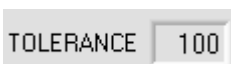

The tolerance value that is currently set at the sensor is shown in a numerical display field below the graphic display area. If the TOLERANCE potentiometer at the sensor housing is activated, the value for the tolerance that is set at the potentiometer is displayed.

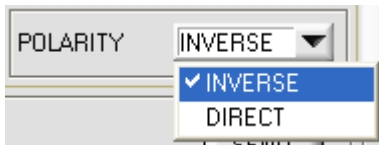

POLARITY:

In this function field the output polarity at the *L-LAS-TB sensor* can be set with a mouse-click. The *L-LAS-TB sensor* has 3 digital outputs (OUT0, OUT1, OUT2) through which error states can be sent to the PLC.

DIRECT:

In case of an error, the respective digital output is set to +Ub (+15DC ... +30VDC), (red LED on).

INVERSE:

In case of an error, the respective digital output is set to the reference potential (GND,0V), (red LED on).

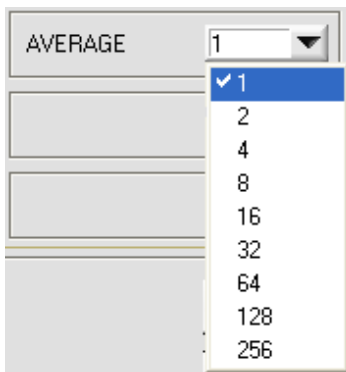

AVERAGE:

In this function field the averaging at the *L-LAS-TB sensor* can be selected with a mouse-click on the respective list item. With every cycle of the main program the current measurement value is stored in a ring memory field, and then the average of these values in the ring memory field is calculated.

The average of the ring memory field is used as the MEASUREMENT_VALUE. With the AVERAGE value the size of the ring memory can be set from 1 to 256.

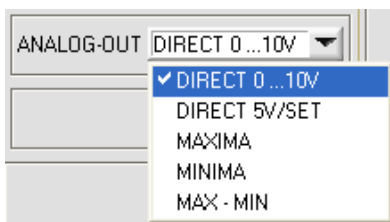

ANALOG-OUT (Analog-Output-Mode):

Function element for selecting the output mode of the analog voltage at the L-LAS- sensor (pin8/red 8-pol. PLC/POWER female connector). The analog voltage is output in the range from 0 to 10V with a resolution of 12 bit.

DIRECT 0..10V :

A voltage (0 .. 10V) that is proportional to the current measurement value is provided at the analog output pin8/red/.

DIRECT 5V/SET:

After the teach process a voltage of +5V (+5V = teach value) is provided at the analog output pin8/red/.

MAXIMA:

The current maximum value is provided at the analog output pin8/red/ (drag pointer principle, resetting by input IN1/pin4/yellow pulse of <750ms length, or by pressing the TEACH/RESET button).

MINIMA:

The current minimum value is provided at the analog output pin8/red/ (drag pointer principle, resetting by input IN1/pin4/yellow pulse of <750ms length, or by pressing the TEACH/RESET button).

MAX-MIN:

The current difference between maximum and minimum value is provided at the analog output pin8/red/ (drag pointer principle, resetting by input IN1/pin4/yellow pulse of <750ms length, or by pressing the TEACH/RESET button).

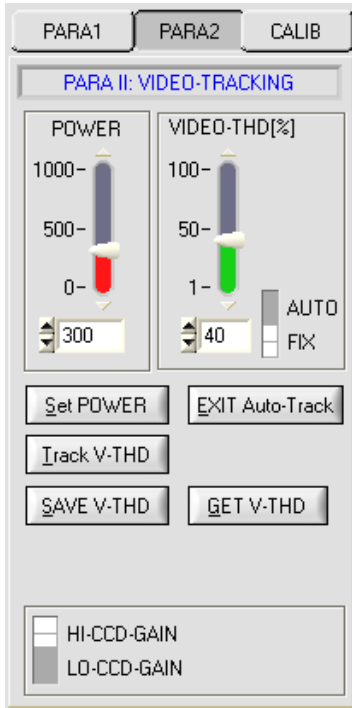

A click on the PARA 2 button opens the PARAMETER II window, where additional parameters at the control unit can be set.



Attention !



Changes that are made in the function fields described below only become active at the control unit of the *L-LAS-TB* sensor after a click on the SEND button!

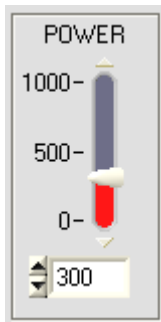

POWER:

In this function field the laser power at the laser transmitter unit of the *L-LAS-TB* sensor can be set by using the arrows or the slider, or by entering a numerical value in the respective input field.

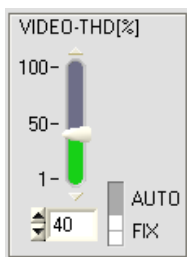

FIX-Video Threshold

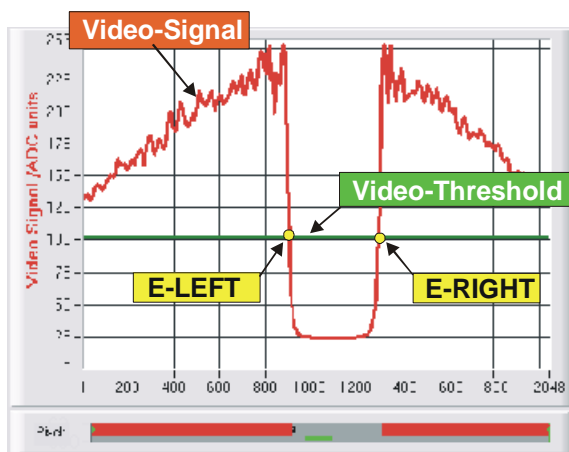

FIX-VIDEO-THD[%]:

In this function field the video threshold at the *L-LAS-TB* sensor can be set by entering a numerical value or by using the slider or the arrows. With the help of this video threshold the measurement values can be derived from the intensity characteristic (video signal) of the CCD line from the bright/dark transitions. For this purpose the intersection points between the intensity profile (red curve) and the adjustable video threshold (green horizontal line) are calculated and stored.

The x-value of the respective intersection point is assigned to a pixel on the CCD line. The measurement value can be calculated from this information and from the known distances of the pixels on the CCD line. The intersection points between intensity profile and video threshold that are provided by this method are hereinafter referred to as edges.

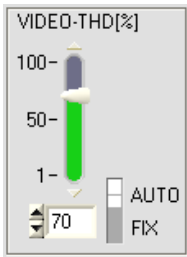

AUTO-Video Threshold

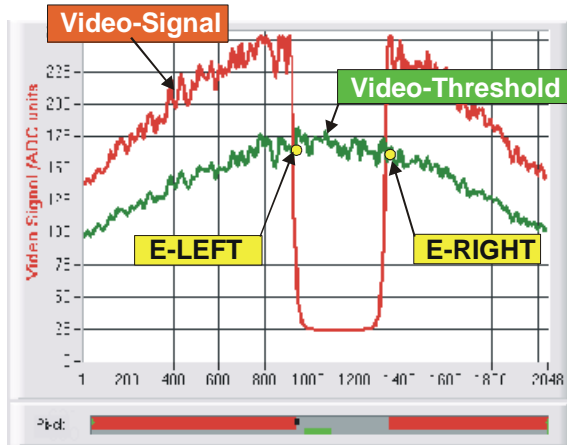

AUTO-VIDEO-THD[%]:

When the toggle switch is in AUTO position, the threshold that is stored in the non-volatile EEPROM of the sensor is used as video threshold.

This threshold (green curve) is not a horizontal line, but is derived from the intensity characteristic of the laser transmitter and thus "tracks" the intensity profile.

As before the measurement values are derived from the intensity characteristic of the CCD line (red curve) and the tracked video threshold (green curve). For this purpose the intersection points between intensity profile and tracked video threshold are calculated again.



Set POWER:

After a click on this software button the laser power at the *L-LAS-* transmitter is automatically regulated in the dynamic range.



Track V-THD:

After a click on this software button the video threshold is automatically derived from the intensity profile. The laser power at the *L-LAS-* transmitter is reduced in steps until the current maximum value of the video profile reaches the value that is set at the VIDEO-THD[%] slider (e.g. 70%). The intensity profile that is determined by this method is referred to as a "tracked" video threshold and can be stored in the EEPROM.



Manual setting of the auto video threshold (Track-VTHD not used!):

The automatic video tracking can be replaced by a manual procedure:

- 1) Take care that the light-measuring section is free (uncovered -no object in laser beam).
- 2) Reduce manually the laser power with the use of the POWER-slider.
Watch the position of the intensity profile by using the features of the VIDEO button.
- 3) Save the actually intensity profile as the new video-threshold by a click on the SAVE-V-THD software button.
- 4) Switch back the laser power (increase) to the initial value with the POWER slider.



SAVE V-THD:

A click on this software button saves the current intensity profile as a new video threshold to the non-volatile EEPROM of the *L-LAS-* sensor.



GET V-THD:

After a click on this software button the video threshold that is currently saved in the EEPROM will be automatically shown in the graphic display window.

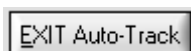

EXIT Auto-Track:

A click on this software button closes automatic threshold finding.

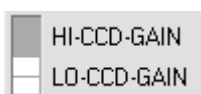

CCD-GAIN:

With this toggle switch the gain stage at the CCD pre-amplifier electronics can be set in 2 steps.

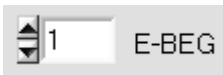

E-BEG:

Numeric input field for entering the beginning of evaluation. The CCD line is evaluated starting from the pixel that is set here (Evaluation-Begin). (Default value = 1)

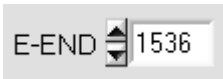

E-END:

Numeric input field for entering the end of evaluation. The CCD line is evaluated up to this pixel. Pixels on the right side of the pixel value that is set here will not be evaluated.

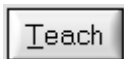

TEACH-Edge:

After a click on the TEACH button the current edge information is stored as a teach value to the RAM memory of the *L-LAS-TB sensor*. Depending on the evaluation mode that has been set (E-MODE), the left edge, the right edge, the width (WIDTH), or the center position (CENTER) will be stored as a teach value in the RAM memory of the L-LAS sensor.

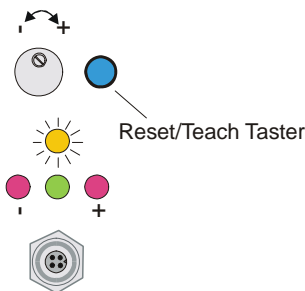

When the teach process is completed, the yellow LED at the housing of the *L-LAS-TB sensor* quickly blinks 3 times.

The teach process also can be started by means of the TEACH/RESET button at the housing (pressing the button for $t > 1.5s$) or by way of a high level at digital input IN1/yellow/pin4 ($t > 1.5s$).

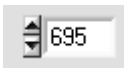

It is furthermore possible to set the current teach value (setpoint value) by entering a numerical value in the numeric input field. The teach value that is set by this method will only be activated at the L-LAS-TB sensor after a click on the SEND button.



The newly taught setpoint value can be read out through the serial interface by clicking on the GET button.

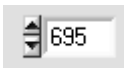
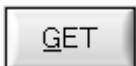

The new teach value is then shown in the TEACH display field.



Reset button (maximum-minimum values):

A click on the Reset button resets the current maximum and minimum values that are detected by the L-LAS sensor. The numeric display fields show the respective current maximum and minimum value.

Resetting of the maximum and minimum values also can be triggered by a short pulse (duration $t < 750$ ms) at digital input IN1/yellow/pin4 from the PLC. The maximum and minimum values also can be reset by pressing the hardware button at the housing of the L-LAS sensor.

Please note:

This reset function does not perform a hardware/software reset at the *L-LAS sensor*, it only resets the maximum and minimum values!

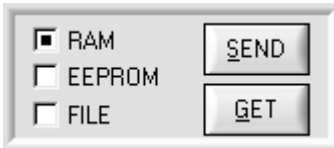

PARAMETER TRANSFER:

This group of function buttons is used for transferring parameters between the PC and the *L-LAS-TB control unit* through the serial RS232 interface.

SEND:

When the SEND button is clicked, the parameters currently set on the user interface are transferred to the *L-LAS-TB control unit*. The target of data transfer is determined by the selected radio-button (RAM, EEPROM, or FILE).

GET:

When the GET button is clicked, the setting parameters are transferred from the *L-LAS-TB control unit* to the PC and are updated on the user interface. The source of data transfer again is determined by the selected radio-button:

RAM:

The currently set parameters are written to the volatile RAM memory of the *L-LAS-TB control unit*, or they are read from the RAM and transferred to the PC. Please note: The parameters set in the RAM will be lost when the power supply at the *L-LAS-TB control unit* is turned off.

EEPROM:

The currently set parameters are written to the non-volatile EEPROM memory of the *L-LAS-TB control unit*, or they are read from the EEPROM and transferred to the PC. Parameters that are saved in the EEPROM will not be lost when the power supply is turned off.

If parameters are read from the EEPROM of the *L-LAS-TB control unit*, these must be written to the RAM of the *L-LAS-TB control unit* by selecting the RAM button and then clicking on SEND. The *L-LAS-TB control unit* then continues to operate with the set RAM parameters.

FILE:

When the FILE radio-button is selected, a click on the SEND/GET button opens a new file dialog on the user interface. The current parameters can be written to a freely selectable file on the hard disk of the PC, or parameters can be read from such a file.

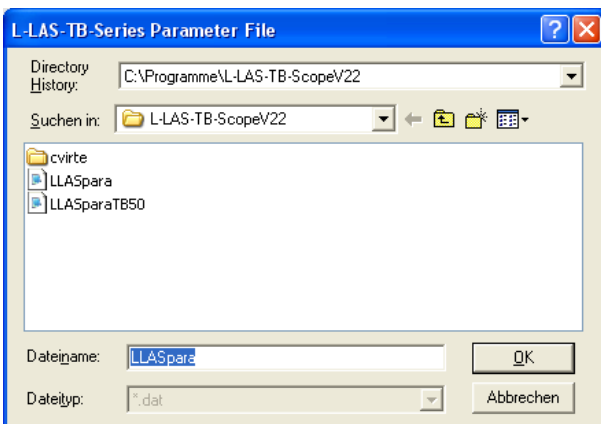

FILE dialog window:

The standard output file for the parameter values has the file name "LLASpara.dat".

The output file can be opened e.g. with the standard Windows "Editor" program.

3.2 Numeric and graphic display elements:



VIDEO button:

After a click on the VIDEO button, the intensity profile measured at the CCD receiver is transferred to the PC and is shown as a red curve in the graphic display window.

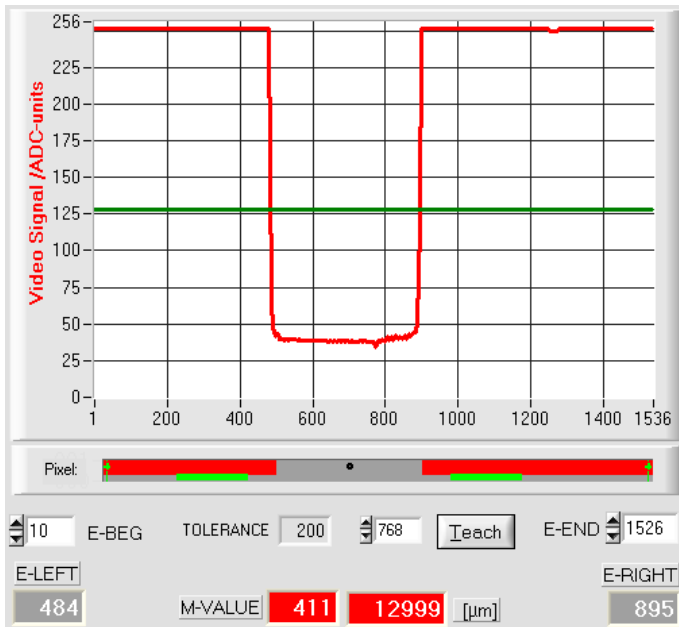

The y-axis shows the analog signals of the individual pixels. The analog values (video signals) of the CCD line are converted by means of an AD converter with 10-bit resolution, which results in a y-axis value range of 0 .. 255.

The currently set video threshold (V-THD) is shown as a green horizontal line in the graphic display. The edge values (pixels) are derived from the intersection points of the intensity profile (red line) with the video threshold (green line).

The x-axis shows a virtual representation of the individual pixels of the CCD line (for example: Pixel 1 .. 1536).

Because of the limited data transfer rate of the serial interface (19200 Baud/s) the graphic display window can only be updated every second.

Beneath the graphic display window there is another display element that shows the currently detected shadowed areas and the illuminated areas of the CCD line. Furthermore the currently detected edge position is indicated in this display element by way of a black circular cursor. A green horizontal bar represents the width of the tolerance band that is currently set around the teach value.



E-LEFT:

Numeric display field that shows the current left edge position.



E-RIGHT:

Numeric display field that shows the current right edge position.



M-VALUE:

Numeric display field that shows the current measurement value (depending on the set evaluation mode).

The left numeric display field shows the current measurement value in pixels, whereas the right display field shows the measurement value converted into micrometers.



RUN button:

After a click on the RUN button, the current measurement data will be transferred from the L-LAS-TB sensor to the PC via the serial interface.

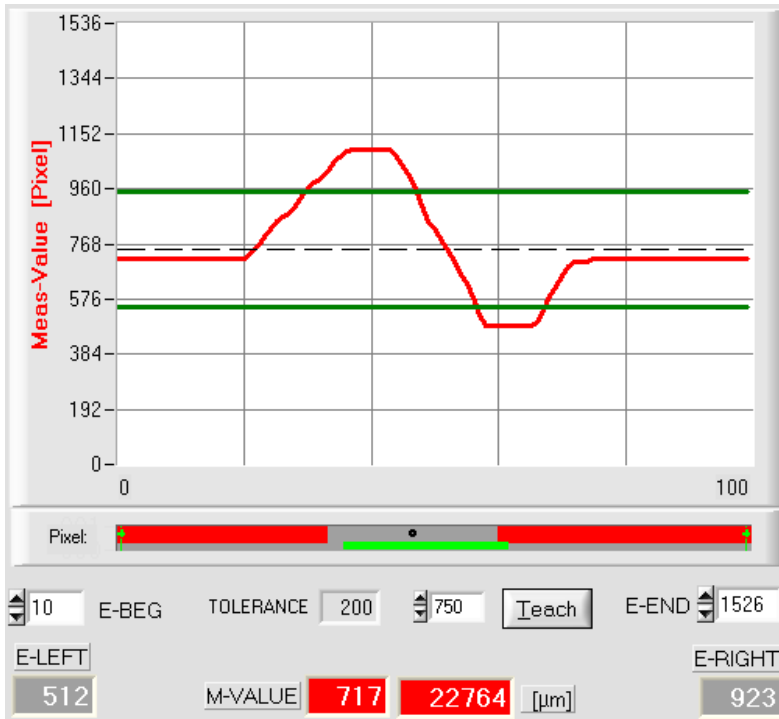

After a click on the RUN button the current measurement value is shown in the graphic display window in "scroll mode". In the form of a red curve the measurement values pass through the graphic display window from the right to the left.

The division of the y-axis corresponds with the pixels of the CCD line, or with the virtual number of sub-pixels of the line. In the graphic display the current measurement value (M-VALUE=717) is shown at the right end at the x-value of 100.

The current setpoint value (TEACH value) is shown as a broken horizontal line.

In addition, the current tolerance window is represented by two horizontal green lines that are applied symmetrically around the setpoint value.

In "RUN mode" the length of the data frame is limited to 18 words (36 bytes), which allows faster updating of the numeric and graphic display elements.

Compared to "DATA mode", data transfer through the serial RS232 interface therefore does not take so much time (in DATA mode the intensity information for every pixel must be transferred).

3.3 Serial RS232 data transfer:

RS232 COMMUNICATION:

- Standard RS232 serial interface without hardware-handshake.
- 3-line-connection: GND, TXD, RXD.
- Speed: 19200 baud, 8 data bits, no parity bit, 1 stop bit in binary mode, MSB first.



Attention !

The stable function of the RS232 interface (status message after program start) is a basic prerequisite for data transfer between the PC and the *L-LAS-TB control unit*. Due to the low data transfer rate of the serial RS232 interface (19200 bit/s) only slow changes of the analog values can be observed in the graphic display at the PC. In order to guarantee the maximum switching frequency of the *L-LAS-TB control unit* it is therefore necessary to stop the data exchange during the normal monitoring process (click on the STOP button).

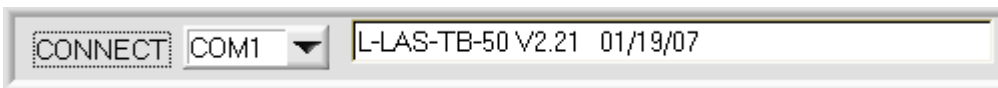

CONNECT:

When the software is started, it attempts to establish a connection to the *L-LAS-TB control unit* through the standard COM1 interface. If connection could be established successfully, the current firmware version is displayed in the status line.

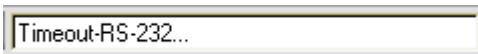

The serial connection between the PC and the *L-LAS-TB control unit* could not be established, or the connection is faulty.

In this case it should first be checked whether the *L-LAS-TB control unit* is connected to the power supply, and whether the serial interface cable is correctly connected to PC and control unit.

If the number of the serial interface that is assigned at the PC should not be known, interfaces COM1 to COM9 can be selected by using the CONNECT drop-down list.

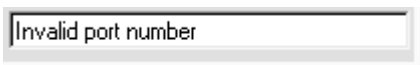

If there is an "Invalid port number" status message, the selected interface, e.g. COM2, is not available at your PC.



If there is a "Cannot open port" status message, the selected interface, e.g. COM2, may already be used by another device.

3.4 L-LAS-TB-Scope as an aid for sensor adjustment:



VIDEO:

After a click on the VIDEO button, the fine adjustment between the L-LAS transmitter unit and the receiver can be observed in the graphic display window. Because of the limited data transfer rate of the RS232 interface the display window can only be updated every second.



STOP:

A mouse-click on the STOP button stops the data transfer between the L-LAS-TB control unit and the PC.

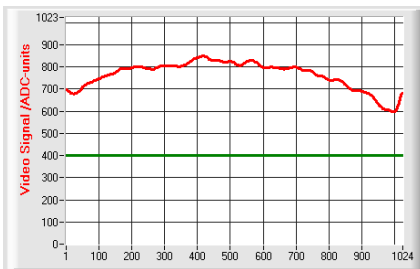

Optimal adjustment:

In the graphic display window the intensity profile is shown as a red curve. The numerical values 1 ... 1024 on the x-axis represent the individual pixels of the CCD line. The analog values of the CCD line are converted by way of an AD converter with 10-bit resolution, which results in a y-axis value range of 0 .. 1023.

As can be seen in the picture on the left, the CCD pixels 1 to 1024 are uniformly illuminated by the transmitter beam.

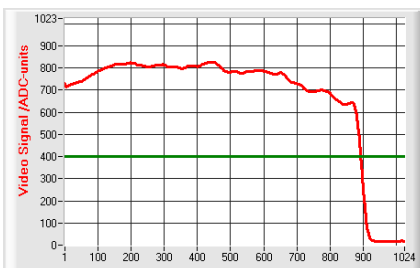

Wrong adjustment - right:

The transmitter beam no longer sufficiently illuminates the pixels at the right end of the CCD line. The red curve (intensity profile) in this part clearly is under the video threshold. The alignment of the laser transmitter unit or the CCD receiver unit must be readjusted in such a way that the pixels at the right end are illuminated again.

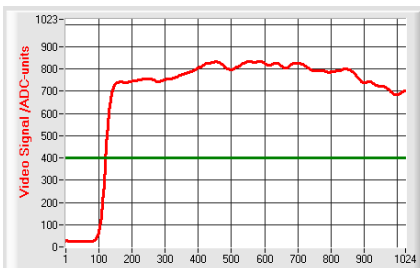

Wrong adjustment - left:

The transmitter beam no longer sufficiently illuminates the pixels at the left end of the CCD line. The alignment of the laser transmitter unit or the CCD receiver unit must be readjusted in such a way that the pixels at the left end are illuminated again.

3.5 L-LAS-TB-Scope as an aid for transmitter power adjustment:

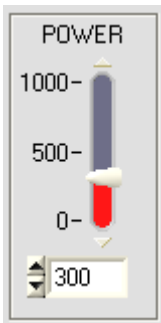

POWER:

In this field the laser power at the laser transmitter unit of the *L-LAS-TB sensor* can be set by using the slider or by entering a numerical value in the respective input field.



Attention !

The laser power at the transmitter unit of the *L-LAS-TB sensor* is only updated when the SEND button is pressed.



VIDEO:

After a click on the VIDEO button, the current intensity profile is transferred from the *L-LAS-TB sensor* to the PC and is shown in the graphic display window. When the VIDEO function is active, the sensor's laser power can be changed (press the SEND button), and the effect of such a change can be observed in the intensity profile.



Optimal adjustment:

In the graphic display window the intensity profile is shown as a red curve. Through the complete CCD line the intensity characteristic lies above the video threshold (green line).

In the shadowed area the intensity characteristic is at low ADC values (offset <120).

In the shadowed areas the intensity characteristic does not show any sporadic "spikes".

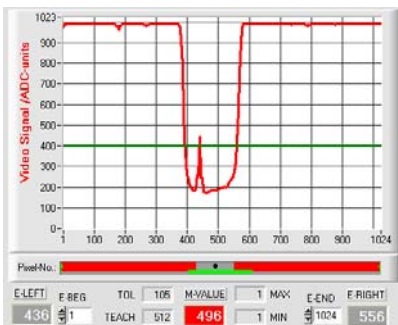

Transmitter power too high:

The transmitter beam overloads individual pixels of the CCD line. There are sporadic short upward "spikes" in the shadowed areas.

If such "spikes" intersect with the green horizontal video threshold, there will be incorrect measurements!

Remedy:

Reduce the laser power in steps, until such "spikes" in the shadowed area do not occur any more.

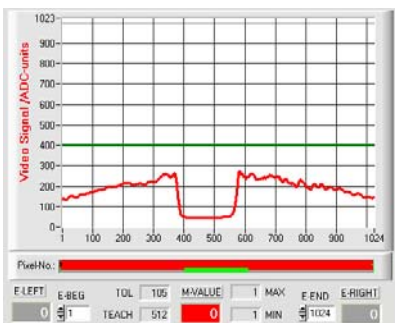

Transmitter power too low:

The intensity profile of the CCD line completely lies under the video threshold (green horizontal line).

The *L-LAS-TB sensor* does not detect any edges (bright/dark transitions, i.e. intersections between red curve and green video threshold) in the image of the beam.

Remedy:

Increase the laser power in steps, at the same time observing the intensity characteristic, until the red curve (intensity profile) from pixel 1 to pixel 1024 lies above the video threshold.

4 Evaluation modes

4.1 LEFT-EDGE



L-EDGE:

The first detected edge in the intensity profile of the CCD line is evaluated.

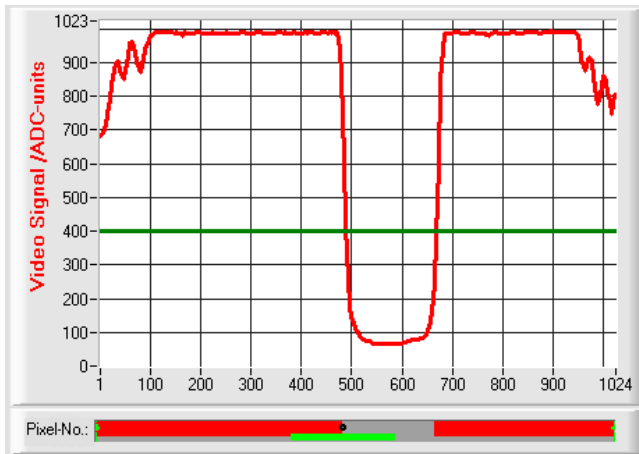

The criterion for edge detection is the transition between illuminated and shadowed areas in the intensity characteristic of the CCD line.

The one pixel of the CCD line at which this bright/dark transition takes place can be determined from the intersection between the video threshold (green horizontal line) and the intensity characteristic (red curve).

In the example picture on the left, the first bright/dark transition is detected at pixel no. 488.

The current measurement value M-VALUE = E-LEFT is shown in the red numeric display element.

4.2 RIGHT-EDGE



R-EDGE:

The second detected edge in the intensity profile of the CCD line is evaluated.

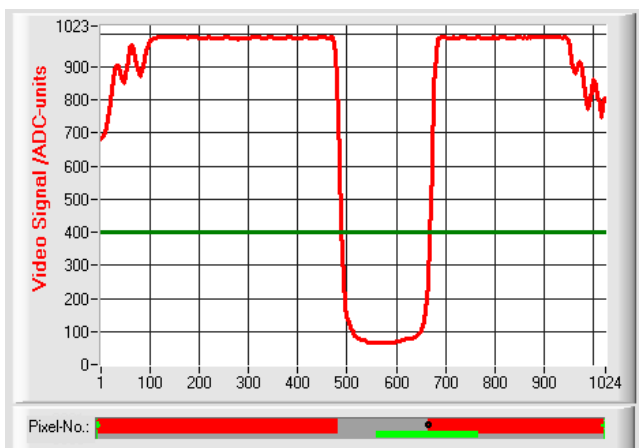

The one pixel of the CCD line at which the second bright/dark transition takes place can be determined from the intersection between the video threshold (green horizontal line) and the intensity characteristic (red curve).

In the example picture on the left, the second bright/dark transition is detected at pixel no. 668.

The black dot-shaped cursor beneath the graphic display window represents the current right edge (R-EDGE) of the shadowed area.

The current measurement value M-VALUE = E-RIGHT is shown in the red numeric display element.

4.3 WIDTH



WIDTH:

The difference between the second edge and the first edge in the intensity profile of the CCD line is evaluated.

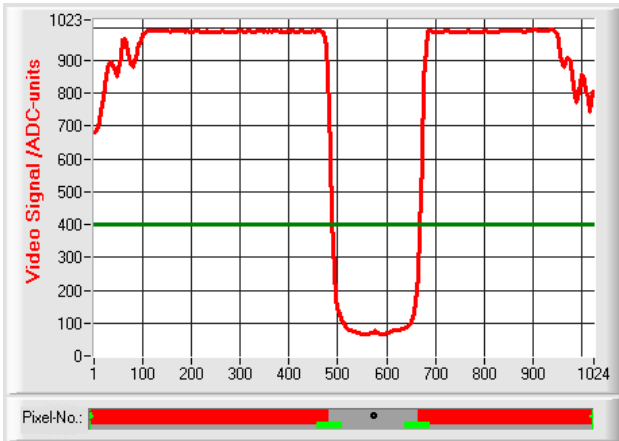

The two pixels where the bright/dark transition occurs can be determined from the two intersections between the video threshold (green horizontal line) and the intensity characteristic (red curve).

In the example picture on the left, the second bright/dark transition is detected at pixel no. 668, and the first bright/dark transition at pixel no. 488.

The difference is calculated as follows:

$$WIDTH = E_RIGHT - E_LEFT$$

The current measurement value M-VALUE = WIDTH is shown in the red numeric display element.

4.4 CENTER



CENTER:

The mean value of the first and the second edge is used as measurement value: $CENTER = (R-EDGE + L-EDGE) / 2$

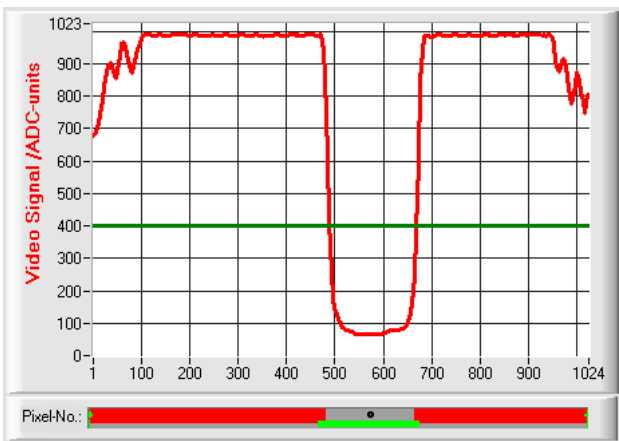

The two pixels where the bright/dark transition occurs can be determined from the two intersections between the video threshold (green horizontal line) and the intensity characteristic (red curve).

In the example picture on the left, the second bright/dark transition is detected at pixel no. 668, and the first bright/dark transition at pixel no. 488.

The mean value is calculated as follows:

$$CENTER = \frac{(E_RIGHT + E_LEFT)}{2}$$

The current measurement value M-VALUE = CENTER is shown in the red numeric display element.

5 Two-point calibration

PARA1
PARA2
CALIB

CCD-CALIBRATION

STEP 1 On/Off Accept

DIAMETER-1 [μm] PIXEL

STEP 2 On/Off Accept

DIAMETER-2 [μm] PIXEL

Calc Calibration: $Y = A * X + B$

SLOPE-VALUE A

INTERSECTION B

SAVE
EXIT NO SAVE !

PARA1
PARA2
CALIB

CCD-CALIBRATION:

EVAL-MODE:

A click on the CALIB button opens the CCD-CALIBRATION window. This CCD-CALIBRATION window allows two-point calibration at the sensor. The purpose of two-point calibration is to provide and output a highly accurate width measurement value in micrometers at the sensor in evaluation mode EVALMODE=WIDTH.

The problem with width measurement is that depending on the set video threshold and the set transmitter power, the measurement value for the width information will be calculated differently. This is caused by the constantly rising analog characteristic (slope) of the video signal in the transition area between object shading and direct laser light impingement on the pixels of the CCD line. The object width is calculated indirectly from the two intersection points of the video signal characteristic (red curve) with the green horizontal video threshold.

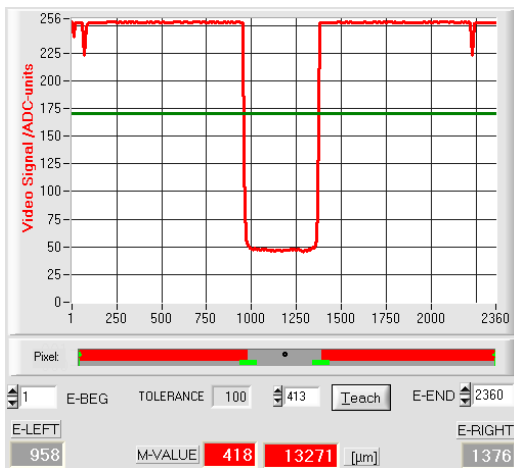

High video threshold, the object appears wider in the "shadow zone". Measured value = 418 pixel. The measured value in μm is calculated from this by multiplying the number of pixels with the respective pixel pitch.

$$M\text{-VALUE} = 418 \text{ pixel} \times 31.75\mu\text{m} = 13271 \mu\text{m}$$

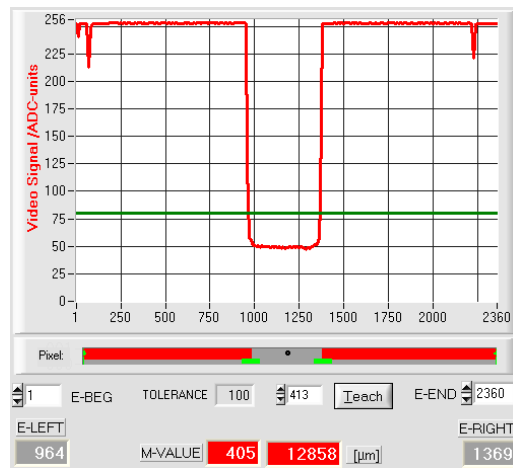

Low video threshold, the object appears somewhat narrower in the "shadow zone". Measured value = 405 pixel. The measured value in μm is calculated from this by multiplying the number of pixels with the respective pixel pitch.

$$M\text{-VALUE} = 405 \text{ pixel} \times 31.75\mu\text{m} = 12858 \mu\text{m}$$

In order to compensate this problem, two-point calibration can be performed with a fixed transmitter power (POWER) and a fixed video threshold (V-THD).

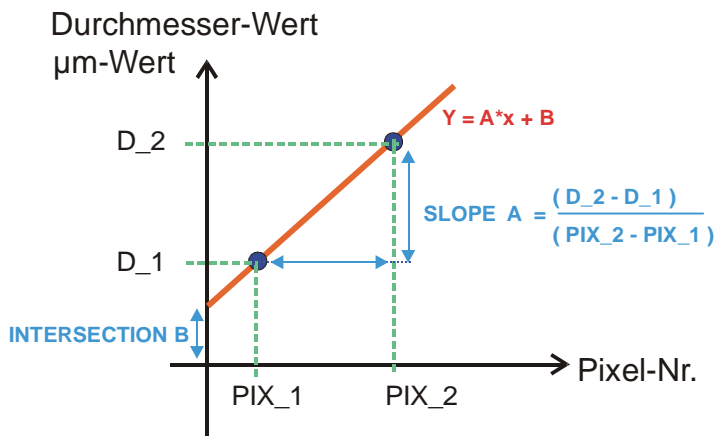

In two-point calibration, a mean straight line through two points is calculated on the basis of two known objects (dimensions in µm are known) of different width.

The most important parameters of this mean straight line are its slope (SLOPE-VALUE A) and, if applicable, the Y-axis section B.

The slope A indicates the change in micrometers per change of pixel. The Y-axis section B (INTERSECTION-VALUE B) defines the zero-point offset.

STEP 1 On/Off

DIAMETER-1 [µm] PIXEL

1500 394

e.g. object of 1.5mm diameter results in 394 pixels covering.

STEP 1:

When the ON/OFF checkmark is activated, the object with the smaller diameter should be placed in the center of the operating range. The smaller object for example should cover 20-40% of the maximum operating range.

The known diameter value in micrometers must then be entered in the numerical input field.

A click on the Accept Object 1 button saves the first value pair (DIAMETER-1, PIXEL₁).

STEP 2 On/Off

DIAMETER-2 [µm] PIXEL

6500 1558

e.g. object of 6.5mm diameter results in 1558 pixels covering.

STEP 2:

When the ON/OFF checkmark is activated, the object with the bigger diameter should be placed in the center of the operating range. The bigger measuring object for example should cover 60-80% of the maximum operating range.

The known diameter value in micrometers must then be entered in the numerical input field.

A click on the Accept Object 2 button saves the second value pair (DIAMETER-2, PIXEL₂).

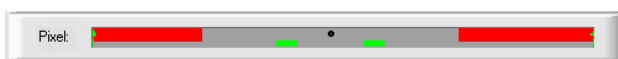

When calibration is started, the actions of the RUN button on the user interface are performed automatically. In the graphic display section under the large "scroll graph" the centered placing of the objects in the operating range of the sensor can be checked. The area with the grey background (shadow area) represents the position of the object. The pixels that are hit by the laser beam are represented as red areas.

SLOPE-VALUE A		INTERSECTION B	
31.750	31.522	0.0	44.5
SAVE NEW VALUES		EXIT CALIBRATION	

Calculate Calibration: $Y = A * X + B$

After a click on the Calculate Calibration button, the slope and the Y-axis section are calculated anew from the two known point pairs of the objects.

The newly calculated values for the slope (SLOPE-VALUE A) and for the offset (INTERSECTION B) are shown in the display fields with gray background.

The previously set values are shown in the numerical input fields with white background.

SAVE NEW VALUES

SAVE NEW VALUES

If the newly calculated values make sense, they can be saved to the RAM memory of the control unit in the sensor by clicking on the SAVE NEW VALUES button.

If the last calibration should be discarded, this can be done by clicking on the EXIT CALIBRATION button.

<input type="checkbox"/> RAM	SEND
<input checked="" type="checkbox"/> EEPROM	
<input type="checkbox"/> FILE	GET



The last calculated calibration values are only saved to the NON-VOLATILE EEPROM memory of the control unit when EEPROM is selected as the target and the SEND button is then pressed!

EXIT CALIBRATION

EXIT CALIBRATION

Exits calibration and discards the calibration values.

Manual entering of calibration data:

SLOPE-VALUE A		INTERSECTION B	
31.521	31.522	44.0	44.5

<input checked="" type="checkbox"/> RAM	SEND
<input type="checkbox"/> EEPROM	
<input type="checkbox"/> FILE	GET

The calibration data also can be modified manually at the control unit of the sensor.

When the PARA II pop-up window has been opened, the numerical values can at any time be changed manually in the corresponding numerical input fields, without having to go through the calibration procedure.

The newly entered calibration values must first be activated at the control unit by clicking on the SEND button.

6 Annex

6.1 Laser warning

LASER WARNING

Solid-state laser, $\lambda=670$ nm, 1mW max. optical power,
laser class 2 acc. to EN 60825-1

Therefore no additional protective measures are required for the use of these laser transmitters.



Nicht
in den Strahl
blicken
Laser Klasse 2

6.2 Function of the Teach/Reset button

The housing of the *L-LAS-TB* sensor features a pushbutton with two functions:

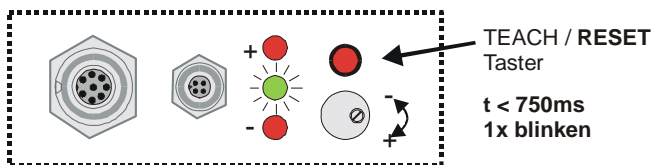

RESET function:

When the button is pressed for a short time ($t < 750\text{ms}$), the current maximum and minimum values are reset.

A hardware/software RESET is not performed!

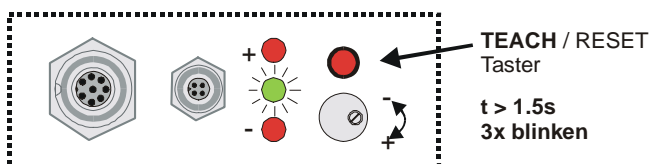

TEACH function:

When the button is pressed for a longer time ($t > 1.5\text{s}$), the current edge coverings are stored as teach value in the RAM memory. When the teach process has been performed successfully, the green LED blinks three times.

6.3 Function of the Tolerance potentiometer:

The housing of the *L-LAS-TB sensor* features a potentiometer for setting the tolerance band width.

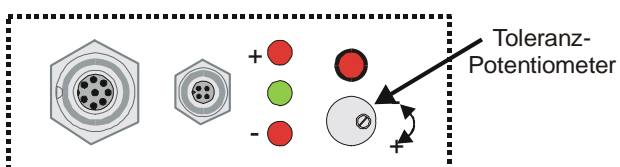

TOLERANCE potentiometer:

Turning the potentiometer clockwise increases the tolerance band width.

Turning it counter-clockwise decreases the tolerance band width.

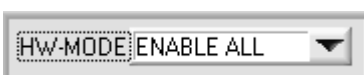

The potentiometer must be activated (switch position **ENABLE ALL** or **ENABLE TOL SET**) in order to use it for setting the tolerance band width at the *L-LAS-TB sensor*.

6.4 Function of digital inputs IN0 and IN1

The *L-LAS-TB sensor* has two digital inputs IN0 and IN1 that can be contacted through the 8-pole female connector (type Binder 712).

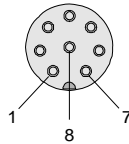
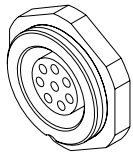

Pin:	Color:	Assignment:
1	white	0V (GND)
2	brown	+12VDC ... +32VDC
3	green	IN0 (EXT TRIGGER)
4	yellow	IN1 (TEACH/RESET)
5	gray	OUT0
6	pink	OUT1
7	blue	OUT2
8	red	ANALOG (0 ... +10V)

DIGITAL INPUT IN0 (pin3/green) EXT-TRIGGER:

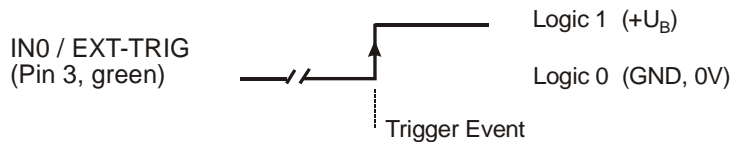

External edge-controlled (LOW/HIGH) triggering of measurement value evaluation through digital input IN0.

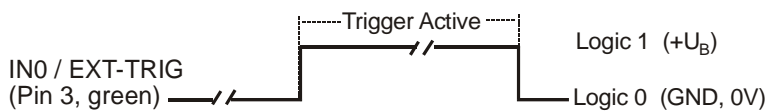

External triggering of measurement value evaluation through a HIGH level (+Ub) at digital input IN0.

DIGITAL INPUT IN1 (pin4/yellow) TEACH/RESET:

RESET function:

When a HIGH pulse of less than **750 ms** duration is applied, the RESET function is performed at the *L-LAS-TB sensor*. This resets the current maximum and minimum values (drag pointer). A hardware/software RESET is not performed! When a RESET pulse is detected, the yellow LED flashes shortly one time.

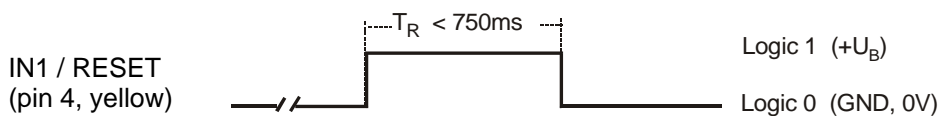

TEACH function:

When a HIGH pulse of more than **1.5s** duration is applied, the TEACH function is performed at the *L-LAS-TB sensor*. When a TEACH pulse is detected, the green LED at the housing flashes shortly three times.

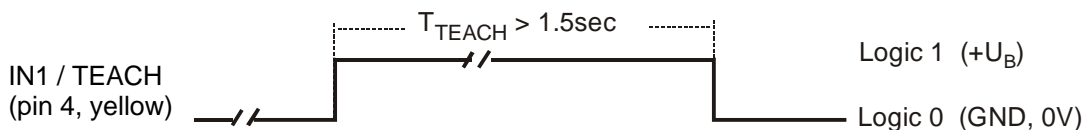

6.5 Connector assignment

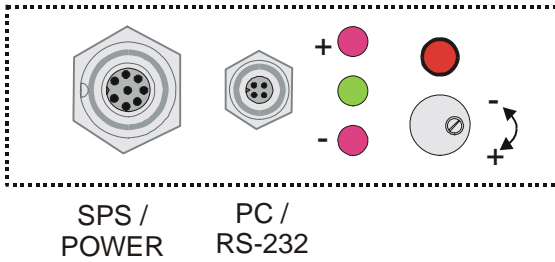

At the housing of the *L-LAS-TB* sensor there is a female connector for power supply connection (8-pol. type Binder 712) and a second female connector for connecting a serial RS232 connecting cable (4-pol. type Binder 707).

RS232 connection to the PC:

4-pole M5 female connector type Binder 707

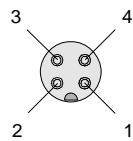

Pin:	Assignment:
1	+24VDC
2	0V (GND)
3	RxD
4	TxD

Connecting cable:

cab-las4/PC (length 2m, cable jacket: PUR)

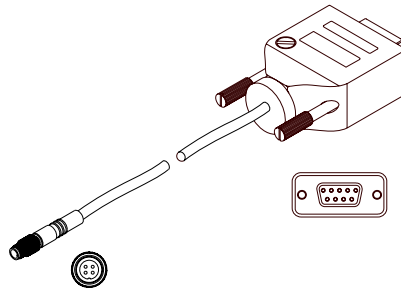

Interface o PLC / power supply:

8-pole female connector type Binder 712

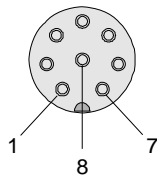
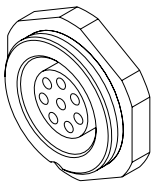

Pin:	Color:	Assignment:
1	white	0V (GND)
2	brown	+12VDC ... +30VDC
3	green	IN0 (EXT TRIGGER)
4	yellow	IN1 (TEACH/RESET)
5	grey	OUT0
6	pink	OUT1
7	blue	OUT2
8	red	ANALOG (0 ... +10V or 4...20mA)

Connecting cable:

cab-las8/SPS (length 2m, cable jacket: PUR)

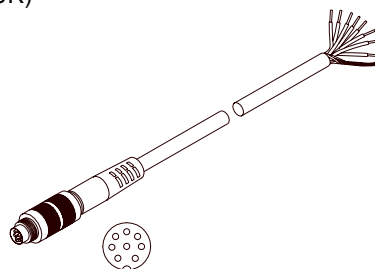

6.6 RS232 interface protocol

RS232 interface protocol PC ↔ L-LAS-TB sensor Firmware version 3.01

- Standard RS232 serial interface, no hardware handshake
 - 3-line connection: GND, TXD, RXD
 - Speed: 19200 baud, 8 data-bits, no parity-bit, 1 stop-bit, binary-mode
- The control device (PC or PLC) must send a data frame consisting of 18-words (1 word = 2 byte = 16 bit) to the L-LAS-TB control unit. All words in the data frame must be transferred in binary format. The higher-order byte must be transferred first (MSB-first).

METHOD:

The microcontroller in the L-LAS-TB sensor permanently reads the input buffer of its RS-232 module (polling). If the arriving word is *0x0055* (*0x55 hexadecimal = 85 decimal*), this is interpreted as a synchronisation event (**<sync-word>**). The microcontroller then reads the order number (**<order-word>**) that is transferred with the 2nd word.

After the order word (**<order-word>**) another word is transferred that informs about the number of the parameter set (**<para-set>**). This is followed by additional 15 words **<parameter-word>** that contain the actual parameters.

When the complete data frame (18 words = 36 bytes) has been read in, the L-LAS-TB control unit starts to execute the order contained in the 2nd word (**<order-word>**)

DATA FRAME: PC/PLC → SENSOR (18-Words=36Bytes, MSB first)

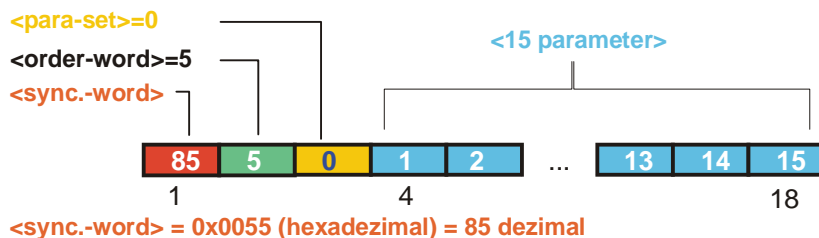

Meaning of the 2nd word in the data frame: <order-word>

Value	Meaning / Action	
0	Nop	no operation
1	Send parameters from PC to L-LAS RAM	18 words, PC ⇒ L-LAS-RAM
2	Get parameters from L-LAS RAM	18 words, L-LAS-RAM ⇒ PC
3	Send parameters from PC to EEPROM	18 words, PC ⇒ L-LAS-EEPROM
4	Get parameters from EEPROM of the L-LAS	18 words, L-LAS-EEPROM ⇒ PC
5	Echo check: Get echo character from L-LAS hardware, Line Ok = 0xAA	18 words, first word=0x00AA (Echo=170)
6	Activate teach process, store in RAM	18 words PC ⇒ L-LAS-RAM
7	Get firmware version message from L-LAS	72-bytes, L-LAS ⇒ PC
8	Get measurement data from L-LAS-RAM	18 words, L-LAS-RAM ⇒ PC
9	Get video buffer information from L-LAS	64 words, L-LAS-RAM ⇒ PC
11	Reset maximum / minimum values	18 words PC ⇒ L-LAS-RAM

Format of the data frame: <para-set = 0>

Word no.	Meaning	Comment
1	<sync-word>	hex-code 0x55, binary=0000 0000 0101 0101, dec.=85
2	<order-word>	Order word (cf. table below)
3	<para-set> = 0	0 = Parameter set zero
4	POWER	Transmitter power (0 ... 1000)
5	VIDEOTHD [%]	Video threshold (0 ... 100) in percent of the ADC range
6	POLARITY	Polarity for OUT0, OUT1,OUT2 (0=DIRECT, 1=INVERSE)
7	EVAL-MODE	Evaluation mode (0=L-EDGE, 1=R-EDGE, 2=WIDTH, 3=CENTER)
8	E-BEGIN	Begin of evaluation, start-pixel (1 .. E_END-1)
9	E-END	End of evaluation range, end-pixel (E_BEG+1 .. SUBPIXEL)
10	TEACH-VALUE	Teach value in pixels (1 ... SUBPIXEL)
11	TOLERANCE-VALUE	Tolerance value TOL: (0 ... SUBPIXEL/2)
12	AVERAGE	Averaging (1,2,4,8,16,32,64,128 or 256)
13	TRIGMODE	Trigger mode (0=CONTINUOUS, 1=EXT. IN0 L/H, 2=EXT.IN0 HIGH)
14	ANALOG-OUT MODE	Operating mode of analog output: (0=DIRECT 0..10V, 1=DIRECT/5V-SET, 2=MAXIMA, 3=MINIMA, 4=MAX-MIN)
15	RS-232-MODE	Currently not used
16	OP-MODE	Operating mode of the CCD line (0=LOW-GAIN / 1=HIGH-GAIN)
17	HARDWMODE	Operating mode of hardware button and potentiometer (DISABLE-ALL=0, ENABLE-ALL=1,ENABLE-BTN=2, ENABLE POTI=3)
18	VIDEO-MODE	Operating mode of the video threshold (0=FIX, 1=AUTO)

Format of the data frame: <para-set = 1>

Word no.	Meaning	Comment
1	<sync-word> = 0x0055	hex-code 0x55, binary=0000 0000 0101 0101, dec.=85
2	<order-word>	Order word (cf. table below)
3	<para-set> = 1	1 = Parameter set one
4	Parameter 1	0 , currently not used
5	Parameter 2	0 , currently not used
6	Parameter 3	0 , currently not used
7	Parameter 4	0 , currently not used
8	Parameter 5	0 , currently not used
9	Parameter 6	0 , currently not used
10	Parameter 7	0 , currently not used
11	Parameter 8	0 , currently not used
12	Parameter 9	0 , currently not used
13	Parameter 10	0 , currently not used
14	Parameter 11	0 , currently not used
15	SLOPE VALUE L-WORD	Sensitivity of the sensor (x 1024), low-order word
16	SLOPE VALUE H-WORD	Sensitivity of the sensor (x1024), higher-order word
17	OFFSET L-WORD	Y-Offset-LW, two-point calibration, low-order word
18	OFFSET H-WORD	Y-Offset HW, two-point calibration, higher-order word

Examples for data exchange:

Echo check: <order-word>=5

<order-word> = 5
 Echo check: The L-LAS-TB sensor sends an echo: word=0x00AA=170 to the PC
 <sync-word>=0x0055 (hexadecimal) = 85 decimal // fill high-byte (MSB) in the word with zero!

DATA FRAME: PC → SENSOR (18-Words=36Bytes, MSB first)
 <para-set>=0
 <order-word>=2
 <sync.-word>

0x55	5	0	0	0	0	0	0	0	0	0	0	0	0	0	0	0	0	0	
										...									
										15 16 17 18									

DATA FRAME: SENSOR → PC (18-Words=36Bytes, MSB first)
 ECHO=0x00AA = 170

170	0	0	0	0	0	0	0	0	0	0	0	0	0	0	0	0	0	0	
										...									
										15 16 17 18									

GET measurement data from L-LAS-RAM <order-word>=8

<order-word> = 8 <para-set> = 0
 Get the current measurement data from the RAM
 <sync-word>=0x0055 (hexadecimal) = 85 decimal // fill high-byte (MSB) in the word with zero!

DATA FRAME: PC → SENSOR (18-Words=36Bytes, MSB first)
 <para-set>=0
 <order-word>=8
 <sync.-word>

0x55	8	0	0	0	0	0	0	0	0	0	0	0	0	0	0	0	0	0	
										...									
										15 16 17 18									

DATA FRAME: SENSOR → PC (18-Words=36Bytes, MSB first)
 <Para-set>= X
 <order-word>=8
 <sync.-word>

0x55	8	1052	1278	1165	10049	1	2048	100	2	110	115	0	2800	800	2	950	0																																																																																																																																																																																																																																																																																																
<table style="width: 100%; border-collapse: collapse;"> <tr> <td style="width: 150px;">E-LEFT</td> <td style="width: 100px;">_____</td> <td style="width: 100px;">_____</td> <td style="width: 100px;">_____</td> <td style="width: 100px;">_____</td> <td style="width: 100px;">_____</td> <td style="width: 100px;">_____</td> <td style="width: 100px;">_____</td> <td style="width: 100px;">_____</td> <td style="width: 100px;">_____</td> <td style="width: 100px;">_____</td> <td style="width: 100px;">_____</td> <td style="width: 100px;">_____</td> <td style="width: 100px;">_____</td> <td style="width: 100px;">_____</td> <td style="width: 100px;">_____</td> <td style="width: 100px;">_____</td> <td style="width: 100px;">_____</td> </tr> <tr> <td>E-RIGHT</td> <td>_____</td> <td>_____</td> <td>_____</td> <td>_____</td> <td>_____</td> <td>_____</td> <td>_____</td> <td>_____</td> <td>_____</td> <td>_____</td> <td>_____</td> <td>_____</td> <td>_____</td> <td>_____</td> <td>_____</td> <td>_____</td> <td>_____</td> </tr> <tr> <td>M-VALUE</td> <td>_____</td> <td>_____</td> <td>_____</td> <td>_____</td> <td>_____</td> <td>_____</td> <td>_____</td> <td>_____</td> <td>_____</td> <td>_____</td> <td>_____</td> <td>_____</td> <td>_____</td> <td>_____</td> <td>_____</td> <td>_____</td> <td>_____</td> </tr> <tr> <td>µm_VALUE (LowWord)</td> <td>_____</td> <td>_____</td> <td>_____</td> <td>_____</td> <td>_____</td> <td>_____</td> <td>_____</td> <td>_____</td> <td>_____</td> <td>_____</td> <td>_____</td> <td>_____</td> <td>_____</td> <td>_____</td> <td>_____</td> <td>_____</td> <td>_____</td> </tr> <tr> <td>µm_VALUE (HighWord)</td> <td>_____</td> <td>_____</td> <td>_____</td> <td>_____</td> <td>_____</td> <td>_____</td> <td>_____</td> <td>_____</td> <td>_____</td> <td>_____</td> <td>_____</td> <td>_____</td> <td>_____</td> <td>_____</td> <td>_____</td> <td>_____</td> <td>_____</td> </tr> <tr> <td>TEACH-VALUE</td> <td>_____</td> <td>_____</td> <td>_____</td> <td>_____</td> <td>_____</td> <td>_____</td> <td>_____</td> <td>_____</td> <td>_____</td> <td>_____</td> <td>_____</td> <td>_____</td> <td>_____</td> <td>_____</td> <td>_____</td> <td>_____</td> <td>_____</td> </tr> <tr> <td>TOL-VALUE</td> <td>_____</td> <td>_____</td> <td>_____</td> <td>_____</td> <td>_____</td> <td>_____</td> <td>_____</td> <td>_____</td> <td>_____</td> <td>_____</td> <td>_____</td> <td>_____</td> <td>_____</td> <td>_____</td> <td>_____</td> <td>_____</td> <td>_____</td> </tr> <tr> <td>EDGE-Number</td> <td>_____</td> <td>_____</td> <td>_____</td> <td>_____</td> <td>_____</td> <td>_____</td> <td>_____</td> <td>_____</td> <td>_____</td> <td>_____</td> <td>_____</td> <td>_____</td> <td>_____</td> <td>_____</td> <td>_____</td> <td>_____</td> <td>_____</td> </tr> <tr> <td>MV-FIRST-8</td> <td>_____</td> <td>_____</td> <td>_____</td> <td>_____</td> <td>_____</td> <td>_____</td> <td>_____</td> <td>_____</td> <td>_____</td> <td>_____</td> <td>_____</td> <td>_____</td> <td>_____</td> <td>_____</td> <td>_____</td> <td>_____</td> <td>_____</td> </tr> <tr> <td>MV-LAST-8</td> <td>_____</td> <td>_____</td> <td>_____</td> <td>_____</td> <td>_____</td> <td>_____</td> <td>_____</td> <td>_____</td> <td>_____</td> <td>_____</td> <td>_____</td> <td>_____</td> <td>_____</td> <td>_____</td> <td>_____</td> <td>_____</td> <td>_____</td> </tr> <tr> <td>FREE-PARA</td> <td>_____</td> <td>_____</td> <td>_____</td> <td>_____</td> <td>_____</td> <td>_____</td> <td>_____</td> <td>_____</td> <td>_____</td> <td>_____</td> <td>_____</td> <td>_____</td> <td>_____</td> <td>_____</td> <td>_____</td> <td>_____</td> <td>_____</td> </tr> <tr> <td>MAX-VALUE</td> <td>_____</td> <td>_____</td> <td>_____</td> <td>_____</td> <td>_____</td> <td>_____</td> <td>_____</td> <td>_____</td> <td>_____</td> <td>_____</td> <td>_____</td> <td>_____</td> <td>_____</td> <td>_____</td> <td>_____</td> <td>_____</td> <td>_____</td> </tr> <tr> <td>MIN-VALUE</td> <td>_____</td> <td>_____</td> <td>_____</td> <td>_____</td> <td>_____</td> <td>_____</td> <td>_____</td> <td>_____</td> <td>_____</td> <td>_____</td> <td>_____</td> <td>_____</td> <td>_____</td> <td>_____</td> <td>_____</td> <td>_____</td> <td>_____</td> </tr> <tr> <td>IN-STATE</td> <td>_____</td> <td>_____</td> <td>_____</td> <td>_____</td> <td>_____</td> <td>_____</td> <td>_____</td> <td>_____</td> <td>_____</td> <td>_____</td> <td>_____</td> <td>_____</td> <td>_____</td> <td>_____</td> <td>_____</td> <td>_____</td> <td>_____</td> </tr> <tr> <td>VIDEO-MAX</td> <td>_____</td> <td>_____</td> <td>_____</td> <td>_____</td> <td>_____</td> <td>_____</td> <td>_____</td> <td>_____</td> <td>_____</td> <td>_____</td> <td>_____</td> <td>_____</td> <td>_____</td> <td>_____</td> <td>_____</td> <td>_____</td> <td>_____</td> </tr> <tr> <td>TRACK-FLAG</td> <td>_____</td> <td>_____</td> <td>_____</td> <td>_____</td> <td>_____</td> <td>_____</td> <td>_____</td> <td>_____</td> <td>_____</td> <td>_____</td> <td>_____</td> <td>_____</td> <td>_____</td> <td>_____</td> <td>_____</td> <td>_____</td> <td>_____</td> </tr> </table>																		E-LEFT	_____	_____	_____	_____	_____	_____	_____	_____	_____	_____	_____	_____	_____	_____	_____	_____	_____	E-RIGHT	_____	_____	_____	_____	_____	_____	_____	_____	_____	_____	_____	_____	_____	_____	_____	_____	_____	M-VALUE	_____	_____	_____	_____	_____	_____	_____	_____	_____	_____	_____	_____	_____	_____	_____	_____	_____	µm_VALUE (LowWord)	_____	_____	_____	_____	_____	_____	_____	_____	_____	_____	_____	_____	_____	_____	_____	_____	_____	µm_VALUE (HighWord)	_____	_____	_____	_____	_____	_____	_____	_____	_____	_____	_____	_____	_____	_____	_____	_____	_____	TEACH-VALUE	_____	_____	_____	_____	_____	_____	_____	_____	_____	_____	_____	_____	_____	_____	_____	_____	_____	TOL-VALUE	_____	_____	_____	_____	_____	_____	_____	_____	_____	_____	_____	_____	_____	_____	_____	_____	_____	EDGE-Number	_____	_____	_____	_____	_____	_____	_____	_____	_____	_____	_____	_____	_____	_____	_____	_____	_____	MV-FIRST-8	_____	_____	_____	_____	_____	_____	_____	_____	_____	_____	_____	_____	_____	_____	_____	_____	_____	MV-LAST-8	_____	_____	_____	_____	_____	_____	_____	_____	_____	_____	_____	_____	_____	_____	_____	_____	_____	FREE-PARA	_____	_____	_____	_____	_____	_____	_____	_____	_____	_____	_____	_____	_____	_____	_____	_____	_____	MAX-VALUE	_____	_____	_____	_____	_____	_____	_____	_____	_____	_____	_____	_____	_____	_____	_____	_____	_____	MIN-VALUE	_____	_____	_____	_____	_____	_____	_____	_____	_____	_____	_____	_____	_____	_____	_____	_____	_____	IN-STATE	_____	_____	_____	_____	_____	_____	_____	_____	_____	_____	_____	_____	_____	_____	_____	_____	_____	VIDEO-MAX	_____	_____	_____	_____	_____	_____	_____	_____	_____	_____	_____	_____	_____	_____	_____	_____	_____	TRACK-FLAG	_____	_____	_____	_____	_____	_____	_____	_____	_____	_____	_____	_____	_____	_____	_____	_____	_____
E-LEFT	_____	_____	_____	_____	_____	_____	_____	_____	_____	_____	_____	_____	_____	_____	_____	_____	_____																																																																																																																																																																																																																																																																																																
E-RIGHT	_____	_____	_____	_____	_____	_____	_____	_____	_____	_____	_____	_____	_____	_____	_____	_____	_____																																																																																																																																																																																																																																																																																																
M-VALUE	_____	_____	_____	_____	_____	_____	_____	_____	_____	_____	_____	_____	_____	_____	_____	_____	_____																																																																																																																																																																																																																																																																																																
µm_VALUE (LowWord)	_____	_____	_____	_____	_____	_____	_____	_____	_____	_____	_____	_____	_____	_____	_____	_____	_____																																																																																																																																																																																																																																																																																																
µm_VALUE (HighWord)	_____	_____	_____	_____	_____	_____	_____	_____	_____	_____	_____	_____	_____	_____	_____	_____	_____																																																																																																																																																																																																																																																																																																
TEACH-VALUE	_____	_____	_____	_____	_____	_____	_____	_____	_____	_____	_____	_____	_____	_____	_____	_____	_____																																																																																																																																																																																																																																																																																																
TOL-VALUE	_____	_____	_____	_____	_____	_____	_____	_____	_____	_____	_____	_____	_____	_____	_____	_____	_____																																																																																																																																																																																																																																																																																																
EDGE-Number	_____	_____	_____	_____	_____	_____	_____	_____	_____	_____	_____	_____	_____	_____	_____	_____	_____																																																																																																																																																																																																																																																																																																
MV-FIRST-8	_____	_____	_____	_____	_____	_____	_____	_____	_____	_____	_____	_____	_____	_____	_____	_____	_____																																																																																																																																																																																																																																																																																																
MV-LAST-8	_____	_____	_____	_____	_____	_____	_____	_____	_____	_____	_____	_____	_____	_____	_____	_____	_____																																																																																																																																																																																																																																																																																																
FREE-PARA	_____	_____	_____	_____	_____	_____	_____	_____	_____	_____	_____	_____	_____	_____	_____	_____	_____																																																																																																																																																																																																																																																																																																
MAX-VALUE	_____	_____	_____	_____	_____	_____	_____	_____	_____	_____	_____	_____	_____	_____	_____	_____	_____																																																																																																																																																																																																																																																																																																
MIN-VALUE	_____	_____	_____	_____	_____	_____	_____	_____	_____	_____	_____	_____	_____	_____	_____	_____	_____																																																																																																																																																																																																																																																																																																
IN-STATE	_____	_____	_____	_____	_____	_____	_____	_____	_____	_____	_____	_____	_____	_____	_____	_____	_____																																																																																																																																																																																																																																																																																																
VIDEO-MAX	_____	_____	_____	_____	_____	_____	_____	_____	_____	_____	_____	_____	_____	_____	_____	_____	_____																																																																																																																																																																																																																																																																																																
TRACK-FLAG	_____	_____	_____	_____	_____	_____	_____	_____	_____	_____	_____	_____	_____	_____	_____	_____	_____																																																																																																																																																																																																																																																																																																

Example µm-Value: 75.584mm = 75584µm = LowWord (10049) + HighWord (1x65535)

SEND parameter set = 0 to L-LAS-RAM <order-word>=1

<order-word> = 1 <para-set> = 0

Send the current parameters (SET=0) to the RAM of the L-LAS-TB sensor

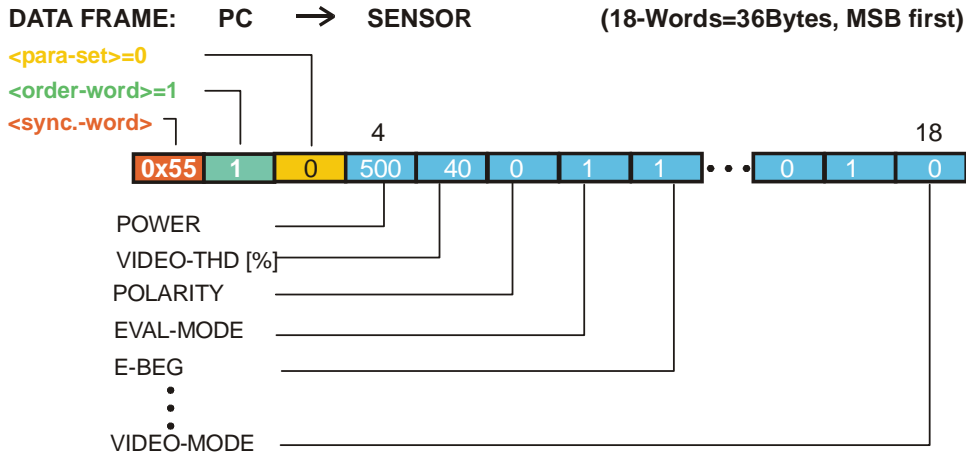

The transferred data frame is automatically sent back as an echo by the L-LAS-TB sensor!!

SEND parameter set = 1 to L-LAS-RAM <order-word>=1

<order-word> = 1 <para-set> = 1

Send the current parameters (SET=1) to the RAM of the L-LAS-TB sensor

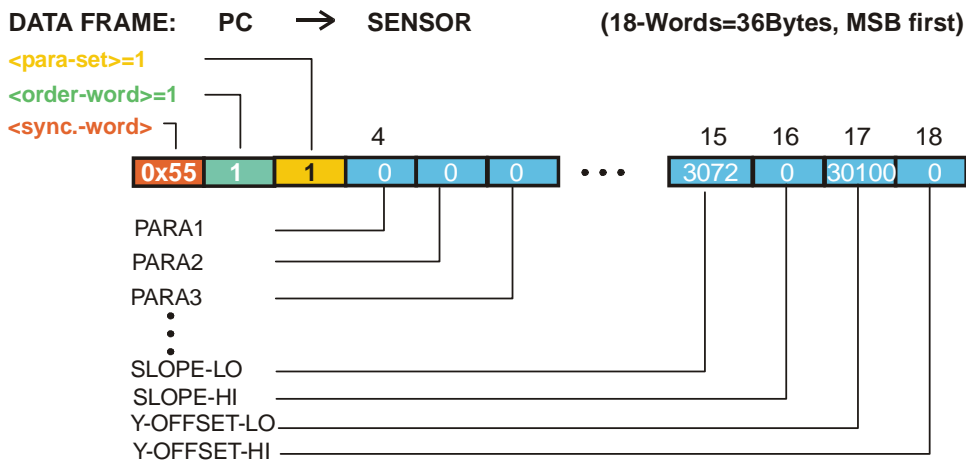

SLOPE-VALUE is multiplied with x1024 e.g. 3.0[μm/pixel] x 1024 = 3072

Y-INTERSECTION-VALUE has offset = 30000 e.g. +100 = 30100

The transferred data frame is automatically sent back as an echo by the L-LAS-TB sensor!!



Attention !

For the final take-over of the full parameter set, both parameter sets (set=0 and set=1) must be transferred.

GET parameter set = 0 from L-LAS-RAM <order-word>=2

<order-word> = 2 <para-set> = 0

Get the current RAM parameters (SET=0) from the L-LAS-RAM

DATA FRAME: PC → SENSOR (18-Words=36Bytes, MSB first)



DATA FRAME: SENSOR → PC (18-Words=36Bytes, MSB first)

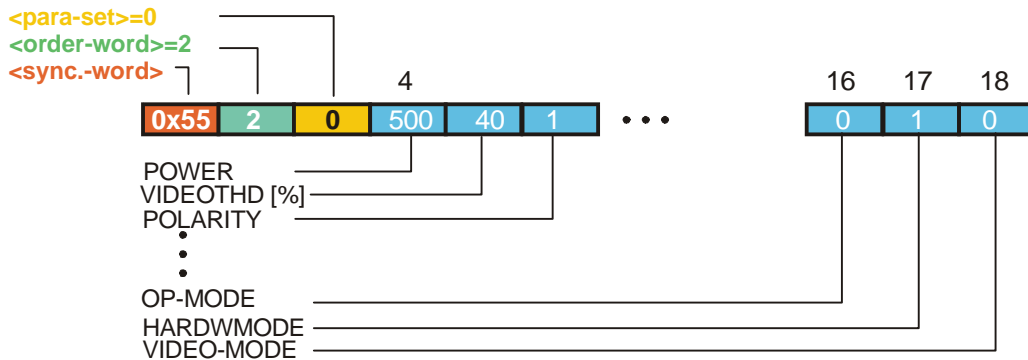

GET parameter set = 1 from L-LAS-RAM <order-word>=2

<order-word> = 2 <para-set> = 1

Get the current RAM parameters (SET=1) from the L-LAS-RAM

DATA FRAME: PC → SENSOR (18-Words=36Bytes, MSB first)



DATA FRAME: SENSOR → PC (18-Words=36Bytes, MSB first)

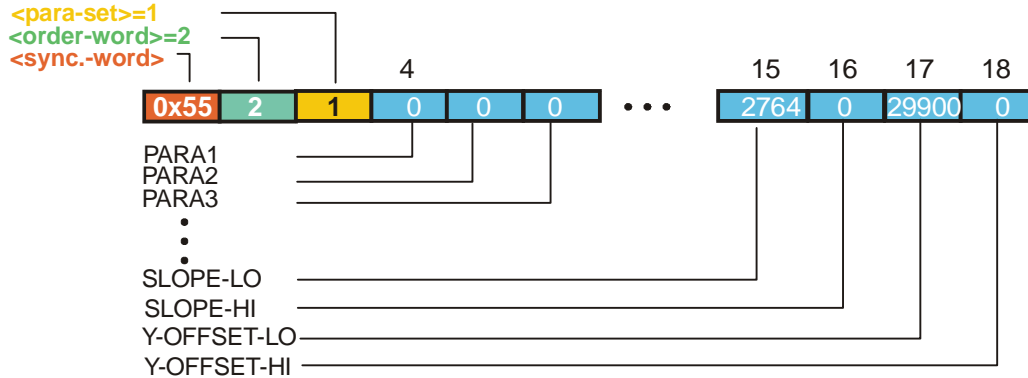

SLOPE-VALUE is multiplied with x1024 e.g. 2.7[$\mu\text{m}/\text{pixel}$] x 1024 = 2764

Y-INTERSECTION -VALUE has offset=30000 e.g. -100 = 29900

GET video data from L-LAS-RAM <order-word> = 9

<order-word> = 9 <para-set> = 0,64,128 or 192

Get the current video data from the RAM (256 pixels, distributed over the CCD line, are read out)

